

GENUINE **METARIS**

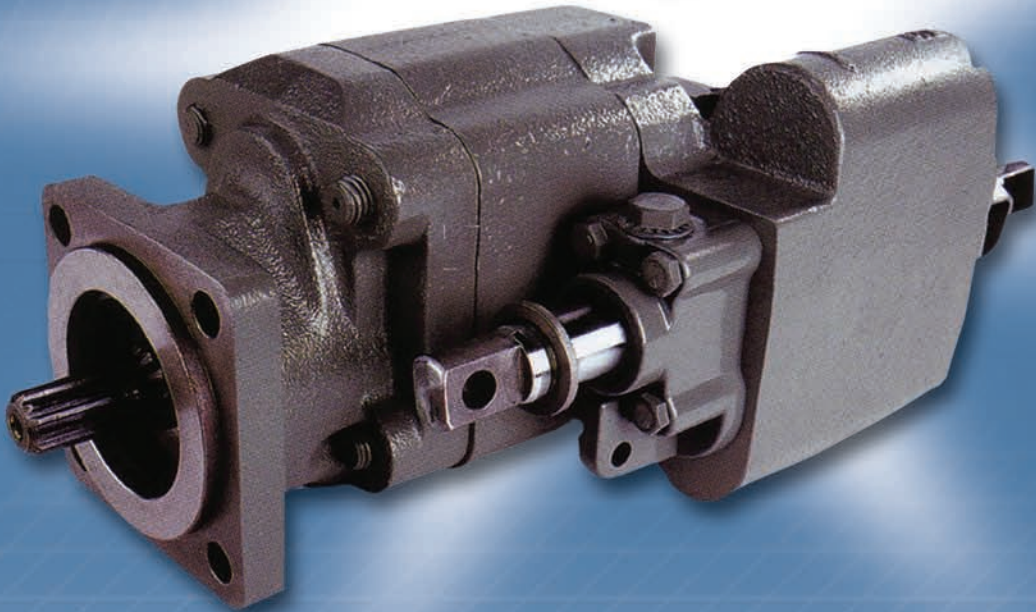
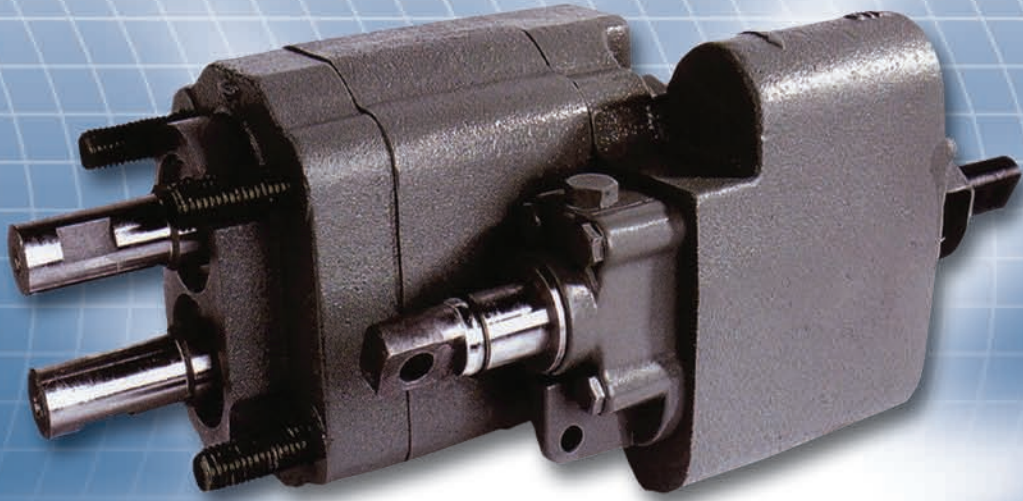

**MH101 / MH102 DUMP PUMPS**

# RUGGED, RELIABLE AND TOTALLY INTERCHANGEABLE

## MH101

- 3 Piece cast iron construction
- High pressure shaft seals
- Direct acting relief c/w load check
- Pressure balance thrust plates
- Heavy-duty roller bearing
- Two or three line hook-up
- Either shaft rotation
- Optional airshift control
- Factory set relief pressure @ 2000 PSI
- Optional mounting bracket
- Dowelled for higher pressure



## MH102

- 3 Piece cast iron construction
- High pressure shaft seals
- Direct acting relief c/w load check
- Pressure balance thrust plates
- Heavy-duty roller bearing
- Two or three line hook-up
- Factory set rotation
- Optional airshift control
- Factory set relief pressure @ 2000 PSI
- Extended studs for support bracket
- Dowelled for higher pressure

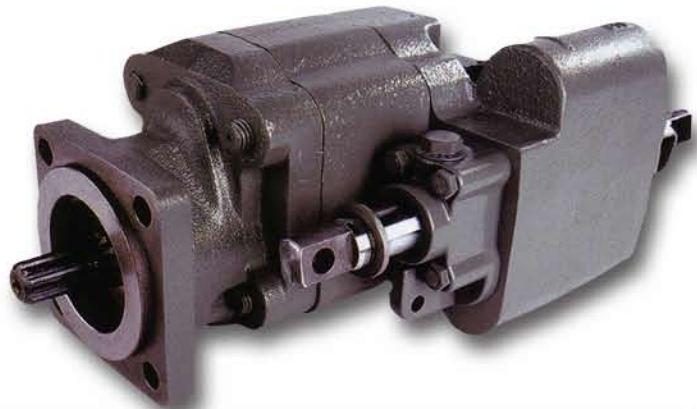

## IMPROVED FEATURES ON MHC SERIES DUMP PUMPS INCLUDE



**Aluminum Detent and Spool Guide Covers**  
Offers greater protection from extreme heat.



**Ductile Housing**  
Only available from Metaris, dramatically increases durability and wear life.

# MH101 - REMOTE MOUNT DIMENSIONS

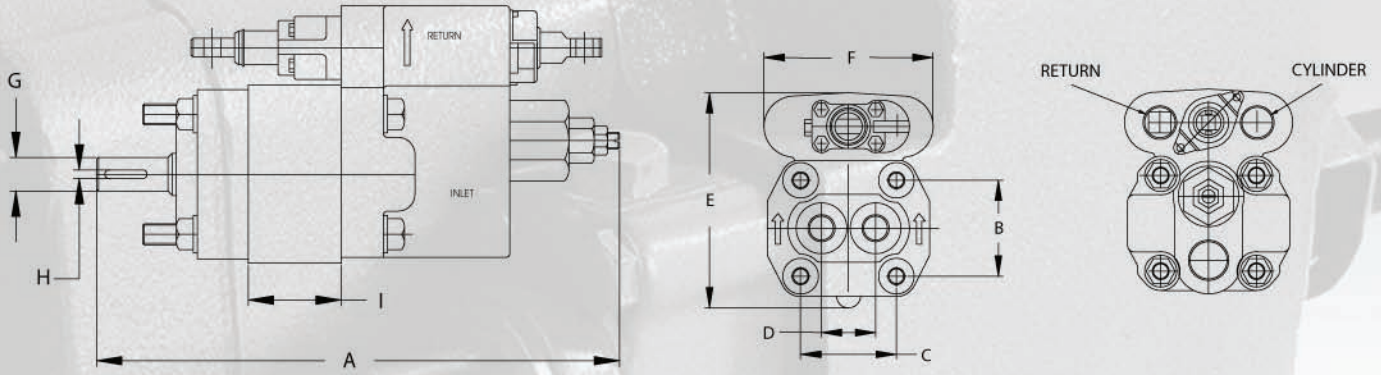

# MH102 - DIRECT MOUNT DIMENSIONS

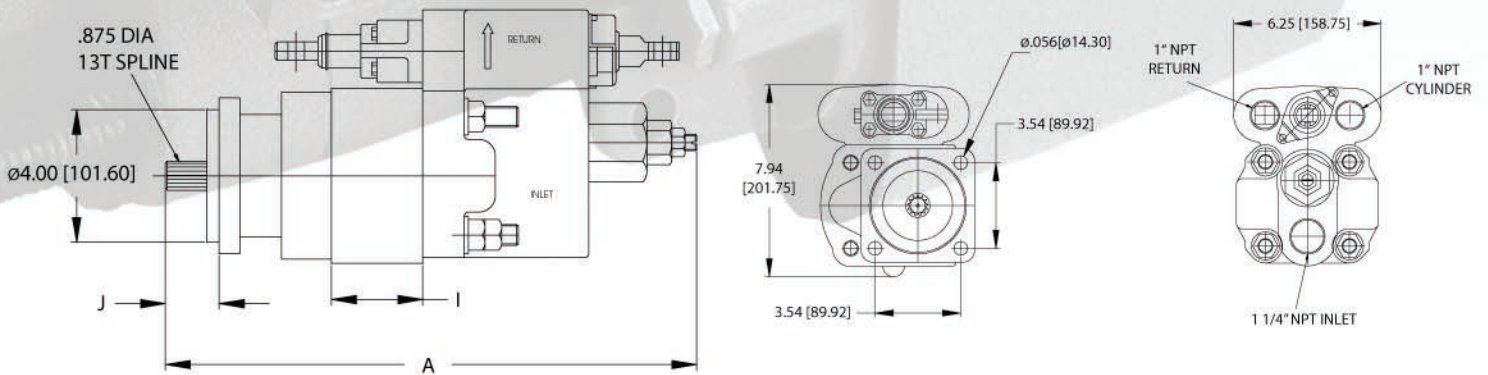

# DIMENSIONS

	A	B	C	D	E	F	G	H	I 25	I 20	I 1.5	I .75	J
MHC101	13.12 + GW	3.56	3.56	2"	7.94	6.25	.998	0.25	3.25	2.75	N/A	N/A	N/A
MHG101	10.56	N/A	N/A	1.75	6.12	5.25	.998	0.25	N/A	2"	0.75	1"	N/A
MHC102	13.62 + GW	N/A	N/A	N/A	7.94	6.25	.875	N/A	3.25	2.75	N/A	N/A	1.62
MHG102	11.38 + GW	N/A	N/A	N/A	7.94	6.25	.875	N/A	N/A	2"	0.75	1"	1.31

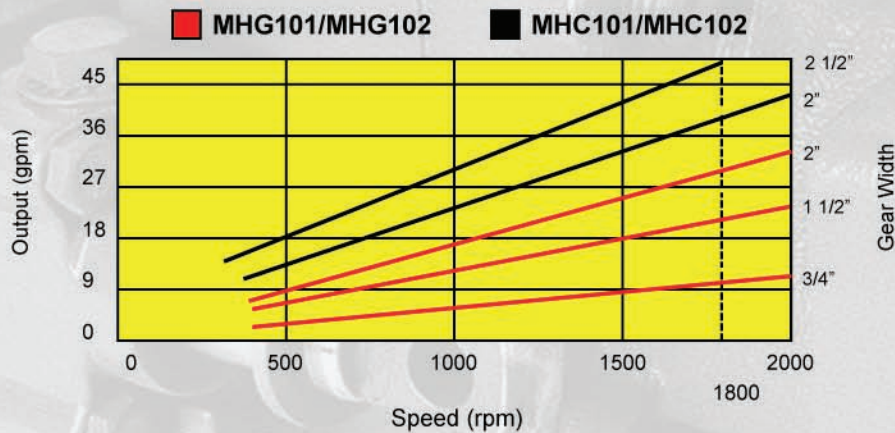

**YOUR SOURCE FOR HIGH QUALITY HYDRAULIC GEAR PUMPS**

## MH101 / MH102 - ORDERING CODES

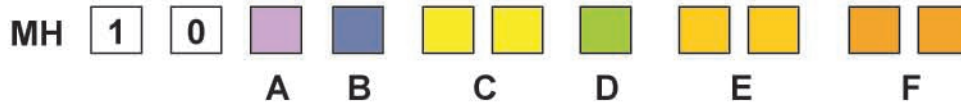

A	1	REMOTE MOUNT
	2	DIRECT MOUNT
B	C	SERIES
	G	SERIES
C	20	5.10 cu in DISPLACEMENT - MH101C & MH102C ONLY
	25	6.38 cu in DISPLACEMENT - MH101C & MH102C ONLY
	0.7	1.48 cu in DISPLACEMENT - MH101G & MH102G ONLY
	1.5	2.96 cu in DISPLACEMENT - MH101G & MH102G ONLY
	2	3.94 cu in DISPLACEMENT - MH101G & MH102G ONLY
D	L	LEFT HAND ROTATION CCW
	R	RIGHT HAND ROTATION CW
E	AS	OPTIONAL AIRSHIFT CONTROL - MH101C & MH102C ONLY
F	FM	OPTIONAL MOUNT BRACKET - MH101C ONLY

Speed RPM	Remote Mount	Direct Mount		3/4"	1 1/2"	2"	2 1/2"
MH101G	✓		GPM	9.5	21	29	-
			LPM	36	79.5	109.3	-
MH102G		✓	GPM	9.5	21	29	-
			LPM	37	79.6	109.4	-
MHC101G	✓		GPM	-	-	39	48
			LPM	-	-	147	180.5
MHC102G		✓	GPM	-	-	39	48
			LPM	-	-	147	180.5

### AIR SHIFT KIT

The Metaris airshift cylinder converts a manual pump into an airshift dump pump. This unit can be factory installed or sold separately.



### L BRACKET

Metaris optional mounting bracket for MHC101.



### Metaris Corp.

1519 Hwy 35 North, Forest, Mississippi 39074  
Tel: (601) 469-1987 / Toll Free 1-800-962-2703  
Fax: (601) 469-2120 / Toll Free: 1-800-654-5083

### Metaris Inc.

1120 Lodestar Rd., Toronto, Ontario M3J 2Z4  
Tel: (416) 638-6000 / Toll Free: 1-800-477-2737  
Fax: (416) 638-9365 / Toll Free: 1-866-638-9365